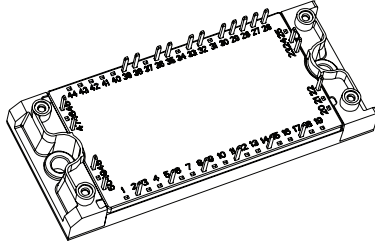

IGBT PIM Module, 21 A

ECONO2 PIM
FEATURES

- Low $V_{CE(on)}$ non punch through IGBT technology
- Low diode V_F
- 10 μ s short circuit capability
- Square RBSOA
- HEXFRED® antiparallel diode with ultrasoft reverse recovery characteristics
- Positive $V_{CE(on)}$ temperature coefficient
- Ceramic DBC substrate
- Low stray inductance design
- Speed 8 to 60 kHz
- Totally lead (Pb)-free
- Designed and qualified for industrial market

RoHS
COMPLIANT

PRODUCT SUMMARY	
V_{CES}	600 V
$V_{CE(on)}$ (typical)	1.89 V
t_{sc} at $T_J = 150\text{ }^\circ\text{C}$	> 10 μ s
I_C at $T_C = 80\text{ }^\circ\text{C}$	21 A

BENEFITS

- Benchmark efficiency for motor control
- Rugged transient performance
- Low EMI, requires less snubbing
- Direct mounting to heatsink
- PCB solderable terminals
- Low junction to case thermal resistance
- UL approved E78996

ABSOLUTE MAXIMUM RATINGS

	PARAMETER	SYMBOL	TEST CONDITIONS	MAX.	UNITS	
Inverter	Collector to emitter voltage	V_{CES}		600	V	
	Gate to emitter voltage	V_{GES}		± 20		
	Continuous collector current	I_C	$T_C = 25\text{ }^\circ\text{C}$	30	A	
			$T_C = 80\text{ }^\circ\text{C}$	21		
	Pulsed collector current See fig. C.T.5	I_{CM}		60	A	
	Diode maximum forward current	I_{FM}	Pulsed	60	A	
	Power dissipation	P_D	One IGBT	25 $^\circ\text{C}$	110	W
Input Rectifier	Repetitive peak reverse voltage	V_{RRM}		800	V	
	Average output current	$I_{F(AV)}$	50/60 Hz sine pulse	80 $^\circ\text{C}$	20	A
	Surge current (non-repetitive)	I_{FSM}	Rated V_{RRM} applied, 10 ms, sine pulse	310		
	I^2t (non-repetitive)	I^2t		525	A ² s	
Brake	Collector to emitter voltage	V_{CES}		600	V	
	Gate to emitter voltage	V_{GES}		± 20		
	Continuous collector current	I_C	$T_C = 25\text{ }^\circ\text{C}$	20	A	
			$T_C = 80\text{ }^\circ\text{C}$	11		
	Pulsed collector current See fig. C.T.5	I_{CM}		40	A	
	Power dissipation	P_D	One IGBT	25 $^\circ\text{C}$	100	W
	Repetitive peak reverse voltage	V_{RRM}		600	V	
	Maximum operating junction temperature	T_J		150	$^\circ\text{C}$	
	Storage temperature range	T_{Sig}		- 40 to + 125		
	Isolation voltage	V_{ISOL}	AC (1 min)	2500		V

ELECTRICAL SPECIFICATIONS ($T_J = 25\text{ }^\circ\text{C}$ unless otherwise noted)							
	PARAMETER	SYMBOL	TEST CONDITIONS	MIN.	TYP.	MAX.	UNITS
Inverter IGBT	Collector to emitter breakdown voltage	$BV_{(CES)}$	$V_{GE} = 0\text{ V}, I_C = 500\text{ }\mu\text{A}$	600	-	-	V
	Temperature coefficient of breakdown voltage	$\Delta V_{(BR)CES}/\Delta T_J$	$V_{GE} = 0\text{ V}, I_C = 1\text{ mA}$ ($25\text{ }^\circ\text{C}$ to $125\text{ }^\circ\text{C}$)	-	0.6	-	$V/^\circ\text{C}$
	Collector to emitter voltage	$V_{CE(on)}$	$I_C = 20\text{ A}, V_{GE} = 15\text{ V}$	-	1.89	2.16	V
			$I_C = 30\text{ A}, V_{GE} = 15\text{ V}$	-	2.24	2.58	
			$I_C = 20\text{ A}, V_{GE} = 15\text{ V}, T_J = 125\text{ }^\circ\text{C}$	-	2.16	2.65	
			$I_C = 30\text{ A}, V_{GE} = 15\text{ V}, T_J = 125\text{ }^\circ\text{C}$	-	2.63	3.22	
	Gate threshold voltage	$V_{GE(th)}$	$V_{CE} = V_{GE}, I_C = 250\text{ }\mu\text{A}$	4	-	6	
	Threshold voltage temperature coefficient	$\Delta V_{GE(th)}/\Delta T_J$	$V_{CE} = V_{GE}, I_C = 1\text{ mA}$ ($25\text{ }^\circ\text{C}$ to $125\text{ }^\circ\text{C}$)	-	-9.6	-	$\text{mV}/^\circ\text{C}$
	Zero gate voltage collector current	I_{CES}	$V_{GE} = 0\text{ V}, V_{CE} = 600\text{ V}$	-	-	100	μA
			$V_{GE} = 0\text{ V}, V_{CE} = 600\text{ V}$ $T_J = 125\text{ }^\circ\text{C}$	-	500	-	
	Gate to emitter leakage current	I_{GES}	$V_{GE} = \pm 20\text{ V}$	-	-	± 200	nA
	Total gate charge (turn-on)	Q_G	$I_C = 20\text{ A}$	-	72	108	nC
	Gate to emitter charge (turn-on)	Q_{GE}	$V_{CC} = 300\text{ V}$	-	16	24	
	Gate to collector charge (turn-on)	Q_{GC}	$V_{GE} = 15\text{ V}$	-	24	36	
	Turn-on switching loss	E_{on}	$I_C = 20\text{ A}, V_{CC} = 300\text{ V}$	-	0.28	0.41	mJ
	Turn-off switching loss	E_{off}	$V_{GE} = 15\text{ V}, R_G = 22\text{ }\Omega$ $L = 200\text{ }\mu\text{H}, T_J = 25\text{ }^\circ\text{C}^{(1)}$	-	0.17	0.25	
	Total switching loss	E_{tot}		-	0.44	0.67	
	Turn-on switching loss	E_{on}	$I_C = 20\text{ A}, V_{CC} = 300\text{ V}$	-	0.40	0.59	
	Turn-off switching loss	E_{off}	$V_{GE} = 15\text{ V}, R_G = 22\text{ }\Omega$ $L = 200\text{ }\mu\text{H}, T_J = 125\text{ }^\circ\text{C}^{(1)}$	-	0.17	0.25	
	Total switching loss	E_{tot}		-	0.56	0.84	
	Turn-on delay time	$t_{d(on)}$	$I_C = 20\text{ A}, V_{CC} = 300\text{ V}$ $V_{GE} = 15\text{ V}, R_G = 22\text{ }\Omega$ $L = 200\text{ }\mu\text{H}, T_J = 125\text{ }^\circ\text{C}$	-	106	159	ns
	Rise time	t_r		-	25	38	
	Turn-off delay time	$t_{d(off)}$		-	128	192	
Fall time	t_f	-		110	165		
Input capacitance	C_{ies}	$V_{GE} = 0\text{ V}$	-	1316	1974	pF	
Output capacitance	C_{oes}	$V_{CC} = 30\text{ V}$	-	335	502		
Reverse transfer capacitance	C_{res}	$f = 1\text{ MHz}$	-	40	60		
Inverter IGBT	Reverse bias safe operating area	RBSOA	$T_J = 125\text{ }^\circ\text{C}, I_C = 50\text{ A}$ $R_G = 22\text{ }\Omega, V_{GE} = 15\text{ V to }0$	Fullsquare			
	Short circuit safe operating area	SCSOA	$T_J = 150\text{ }^\circ\text{C}$ $V_{CC} = 300\text{ V}, V_P = 600\text{ V}$ $R_G = 22\text{ }\Omega, V_{GE} = 15\text{ V to }0\text{ V}$	10	-	-	μs
Inverter Diode	Diode peak reverse recovery current	I_{rr}	$T_J = 125\text{ }^\circ\text{C}$ $V_{CC} = 300\text{ V}, I_F = 20\text{ A}, L = 200\text{ }\mu\text{H}$ $R_G = 22\text{ }\Omega, V_{GE} = 15\text{ V}$	-	36	-	A
	Diode forward voltage drop	V_{FM}	$I_F = 20\text{ A}$	-	1.26	1.57	V
			$I_F = 30\text{ A}$	-	1.38	1.80	
			$I_F = 20\text{ A}, T_J = 125\text{ }^\circ\text{C}$	-	1.21	1.52	
$I_F = 30\text{ A}, T_J = 125\text{ }^\circ\text{C}$			-	1.36	1.78		



ELECTRICAL SPECIFICATIONS ($T_J = 25\text{ }^\circ\text{C}$ unless otherwise noted)							
	PARAMETER	SYMBOL	TEST CONDITIONS	MIN.	TYP.	MAX.	UNITS
Input Rectifier	Maximum forward voltage drop	V_{FM}	$I_F = 20\text{ A}$	-	-	1.18	V
	Maximum reverse leakage current	I_{RM}	$T_J = 25\text{ }^\circ\text{C}, V_R = 800\text{ V}$	-	-	0.2	mA
			$T_J = 150\text{ }^\circ\text{C}, V_R = 800\text{ V}$	-	-	1	
	Forward slope resistance	r_T	$T_J = 150\text{ }^\circ\text{C}$	-	9.8	-	m Ω
Conduction threshold voltage	$V_{F(TO)}$	-		0.75	-	V	
Brake IGBT	Collector to emitter breakdown voltage	$BV_{(CES)}$	$V_{GE} = 0\text{ V}, I_C = 500\text{ }\mu\text{A}$	600	-	-	
	Temperature coefficient of breakdown voltage	$\Delta V_{(BR)CES}/\Delta T_J$	$V_{GE} = 0\text{ V}, I_C = 1\text{ mA}$ ($25\text{ }^\circ\text{C}$ to $125\text{ }^\circ\text{C}$)	-	0.6	-	V/ $^\circ\text{C}$
	Collector to emitter voltage	$V_{CE(on)}$	$I_C = 10\text{ A}, V_{GE} = 15\text{ V}$	-	1.59	1.69	V
			$I_C = 20\text{ A}, V_{GE} = 15\text{ V}$	-	2.06	2.24	
			$I_C = 10\text{ A}, V_{GE} = 15\text{ V}, T_J = 125\text{ }^\circ\text{C}$	-	1.79	2.37	
			$I_C = 20\text{ A}, V_{GE} = 15\text{ V}, T_J = 125\text{ }^\circ\text{C}$	-	2.46	2.79	
	Gate threshold voltage	$V_{GE(th)}$	$V_{CE} = V_{GE}, I_C = 250\text{ }\mu\text{A}$	4	-	6	
	Threshold voltage temperature coefficient	$\Delta V_{GE(th)}/\Delta T_J$	$V_{CE} = V_{GE}, I_C = 1\text{ mA}$ ($25\text{ }^\circ\text{C}$ to $125\text{ }^\circ\text{C}$)	-	-9.1	-	mV/ $^\circ\text{C}$
	Zero gate voltage collector current	I_{CES}	$V_{GE} = 0\text{ V}, V_{CE} = 600\text{ V}$	-	-	100	μA
			$V_{GE} = 0\text{ V}, V_{CE} = 600\text{ V}$ $T_J = 125\text{ }^\circ\text{C}$	-	300	-	
	Gate to emitter leakage current	I_{GES}	$V_{GE} = \pm 20\text{ V}$	-	-	± 200	nA
	Total gate charge (turn-on)	Q_G	$I_C = 10\text{ A}$ $V_{CC} = 300\text{ V}$ $V_{GE} = 15\text{ V}$	-	52	78	nC
	Gate to emitter charge (turn-on)	Q_{GE}		-	12	18	
	Gate to collector charge (turn-on)	Q_{GC}		-	19	29	
	Turn-on switching loss	E_{on}	$I_C = 10\text{ A}, V_{CC} = 300\text{ V}$ $V_{GE} = 15\text{ V}, R_G = 22\text{ }\Omega$ $L = 500\text{ }\mu\text{H}, T_J = 25\text{ }^\circ\text{C}^{(1)}$	-	0.14	0.22	mJ
	Turn-off switching loss	E_{off}		-	0.11	0.16	
Total switching loss	E_{tot}	-		0.25	0.38		
Turn-on switching loss	E_{on}	$I_C = 10\text{ A}, V_{CC} = 300\text{ V}$ $V_{GE} = 15\text{ V}, R_G = 22\text{ }\Omega$ $L = 500\text{ }\mu\text{H}, T_J = 125\text{ }^\circ\text{C}^{(1)}$		-	0.18	0.26	
Turn-off switching loss	E_{off}			-	0.20	0.29	
Total switching loss	E_{tot}			-	0.37	0.56	
Turn-on delay time	$t_{d(on)}$	$I_C = 10\text{ A}, V_{CC} = 300\text{ V}$ $V_{GE} = 15\text{ V}, R_G = 22\text{ }\Omega$ $L = 500\text{ }\mu\text{H}, T_J = 125\text{ }^\circ\text{C}$	-	83	125	ns	
Rise time	t_r		-	18	27		
Turn-off delay time	$t_{d(off)}$		-	112	168		
Fall time	t_f		-	155	233		
Brake IGBT	Input capacitance	C_{ies}	$V_{GE} = 0\text{ V}$ $V_{CC} = 30\text{ V}$ $f = 1\text{ MHz}$	-	904	1356	pF
	Output capacitance	C_{oes}		-	201	302	
	Reverse transfer capacitance	C_{res}		-	29	44	
	Reverse bias safe operating area	RBSOA	$T_J = 150\text{ }^\circ\text{C}, I_C = 20\text{ A}$ $R_G = 22\text{ }\Omega, V_{GE} = 15\text{ V to }0$	Fullsquare			
	Short circuit safe operating area	SCSOA	$T_J = 150\text{ }^\circ\text{C}$ $V_{CC} = 300\text{ V}, V_P = 600\text{ V}$ $R_G = 22\text{ }\Omega, V_{GE} = 15\text{ V to }0$	10	-	-	μs

ELECTRICAL SPECIFICATIONS ($T_J = 25\text{ }^\circ\text{C}$ unless otherwise noted)							
	PARAMETER	SYMBOL	TEST CONDITIONS	MIN.	TYP.	MAX.	UNITS
Brake Diode	Diode peak reverse recovery current	I_{rr}	$V_{CC} = 300\text{ V}$, $I_F = 10\text{ A}$, $L = 500\text{ }\mu\text{H}$ $R_G = 22\text{ }\Omega$, $V_{GE} = 15\text{ V}$ to 0	-	-	-	A
	Diode forward voltage drop	V_{FM}	$I_F = 10\text{ A}$	-	1.31	1.51	V
			$I_F = 20\text{ A}$	-	1.57	1.84	
			$I_F = 10\text{ A}$, $T_J = 125\text{ }^\circ\text{C}$	-	1.25	1.35	
			$I_F = 20\text{ A}$, $T_J = 125\text{ }^\circ\text{C}$	-	1.58	1.69	
NTC	Resistance	R	$T_J = 25\text{ }^\circ\text{C}$	-	5000	-	Ω
			$T_J = 100\text{ }^\circ\text{C}$	-	4933	-	
	B value	B	$T_J = 25\text{ }^\circ\text{C}/50\text{ }^\circ\text{C}$	-	3375	-	K

Note

(1) Energy losses include “tail” and diode reverse recovery

THERMAL AND MECHANICAL SPECIFICATIONS					
PARAMETER	SYMBOL	MIN.	TYP.	MAX.	UNITS
Junction to case inverter IGBT thermal resistance	R_{thJC}	-	-	1.13	$^\circ\text{C}/\text{W}$
Junction to case inverter FRED thermal resistance		-	-	1.69	
Junction to case brake DIODE thermal resistance		-	-	2.99	
Junction to case brake IGBT thermal resistance		-	-	1.25	
Junction to case input rectifier thermal resistance		-	-	1.03	
Case to sink, flat, greased surface	R_{thCS}	-	0.05	-	
Mounting torque (M5)		2.7	-	3.3	Nm
Weight		-	170	-	g

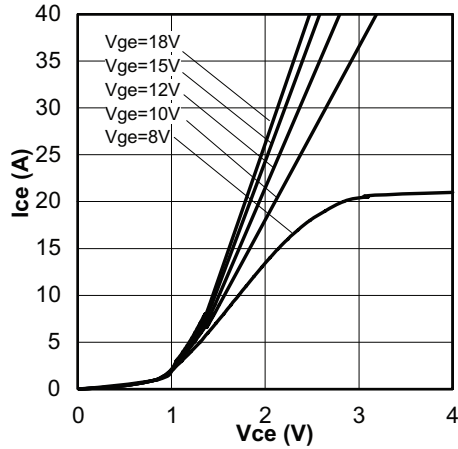
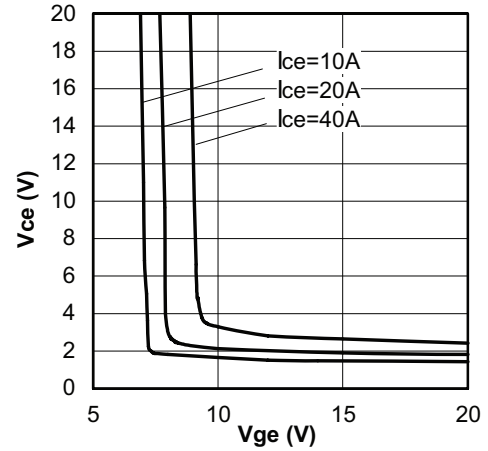
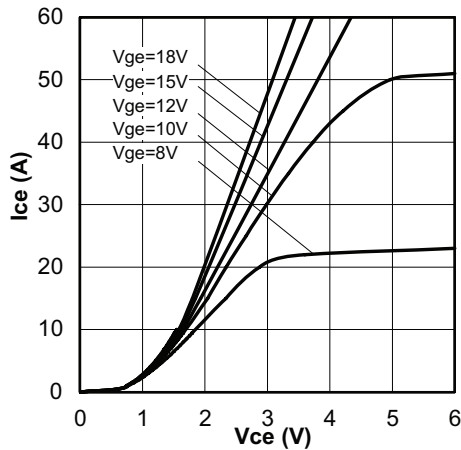
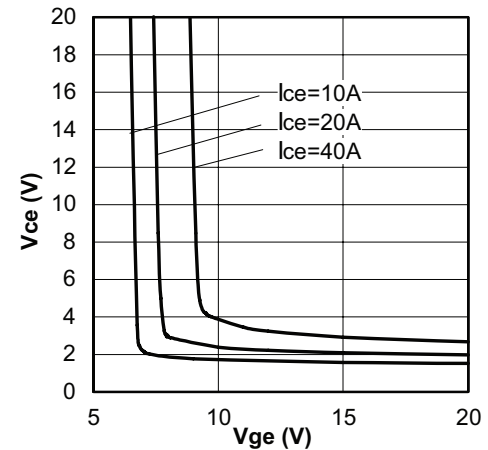
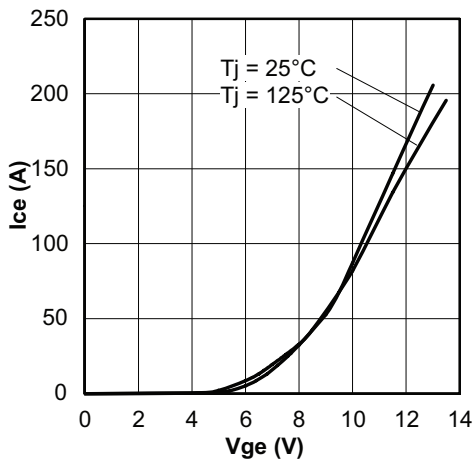
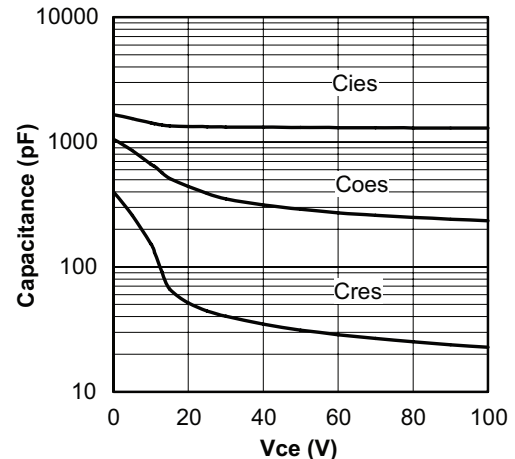
INVERTER

 Fig. 1 - Typical IGBT Output Characteristics
 $T_J = 25^\circ\text{C}$; $t_p = 80\ \mu\text{s}$

 Fig. 4 - Typical V_{CE} vs. V_{GE}
 $T_J = 25^\circ\text{C}$

 Fig. 2 - Typical IGBT Output Characteristics
 $T_J = 125^\circ\text{C}$; $t_p = 80\ \mu\text{s}$

 Fig. 5 - Typical V_{CE} vs. V_{GE}
 $T_J = 125^\circ\text{C}$

 Fig. 3 - Typical Transfer Characteristics
 $V_{CE} = 50\ \text{V}$; $t_p = 10\ \mu\text{s}$

 Fig. 6 - Typical Capacitance vs. V_{CE}
 $V_{GE} = 0\ \text{V}$; $f = 1\ \text{MHz}$

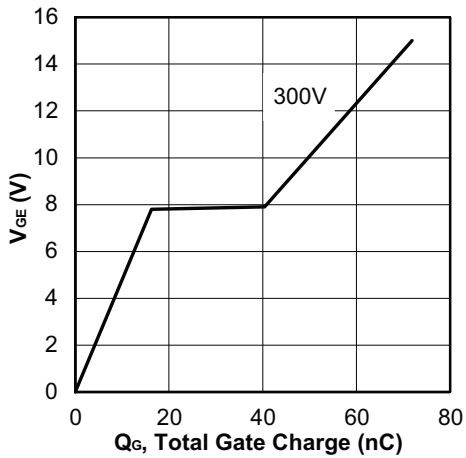

Fig. 7 - Typical Gate Charge vs. V_{GE}
 $I_{CE} = 20 \text{ A}$

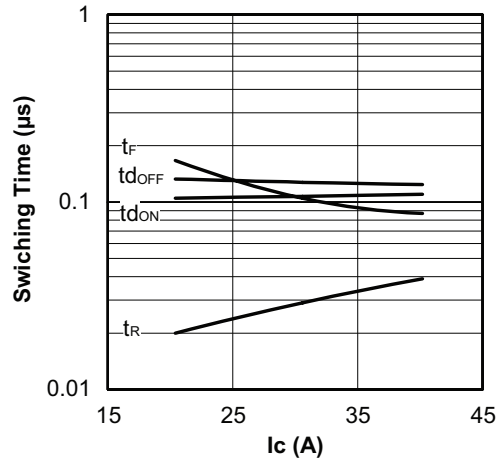

Fig. 10 - Typical Switching Time vs. I_C
 $T_J = 125^\circ\text{C}$; $L = 200 \mu\text{H}$; $V_{CE} = 300 \text{ V}$; $R_G = 22 \Omega$; $V_{GE} = 15 \text{ V}$

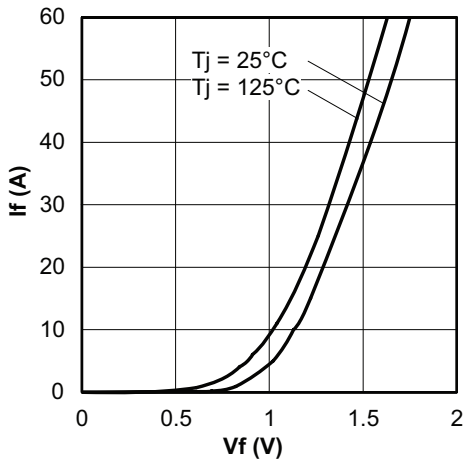

Fig. 8 - Typical Diode Forward Characteristics
 $t_p = 80 \mu\text{s}$

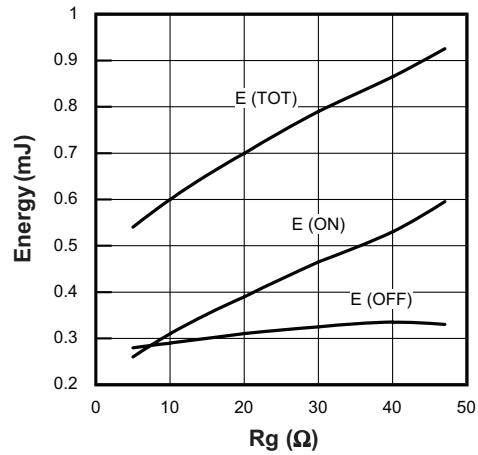

Fig. 11 - Typical Energy Loss vs. R_G
 $T_J = 125^\circ\text{C}$; $L = 200 \mu\text{H}$; $V_{CE} = 300 \text{ V}$; $I_{CE} = 20 \text{ A}$; $V_{GE} = 15 \text{ V}$

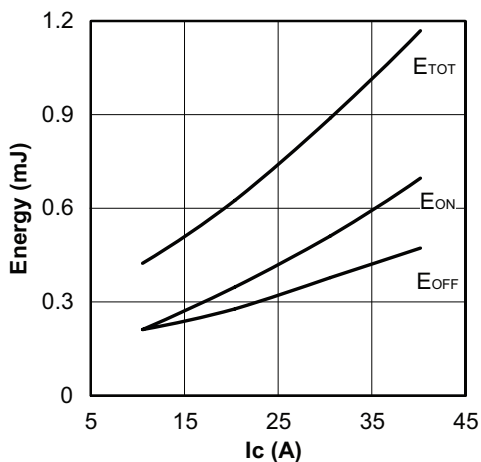

Fig. 9 - Typical Energy Loss vs. I_C
 $T_J = 125^\circ\text{C}$; $L = 200 \mu\text{H}$; $V_{CE} = 300 \text{ V}$; $R_G = 22 \Omega$; $V_{GE} = 15 \text{ V}$

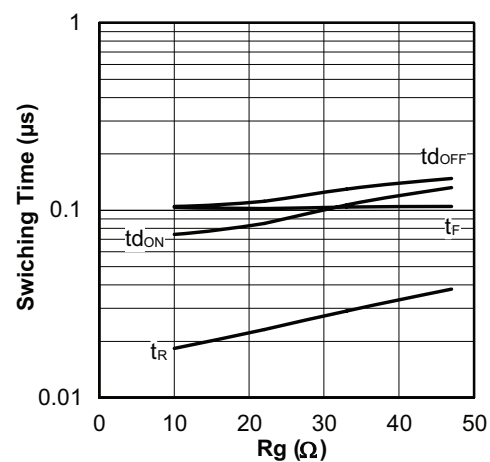

Fig. 12 - Typical Switching Time vs. R_G
 $T_J = 125^\circ\text{C}$; $L = 200 \mu\text{H}$; $V_{CE} = 300 \text{ V}$; $I_{CE} = 20 \text{ A}$; $V_{GE} = 15 \text{ V}$

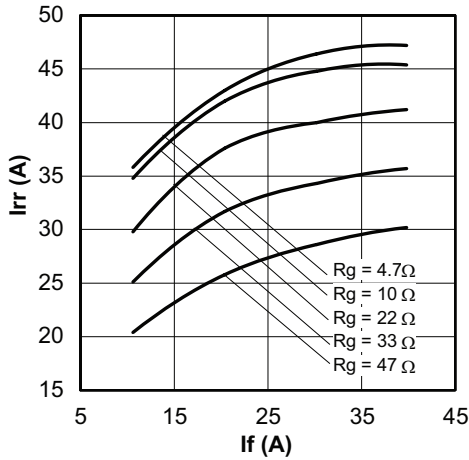

Fig. 13 - Typical Diode I_{RR} vs. I_F
 $T_J = 125^\circ\text{C}$

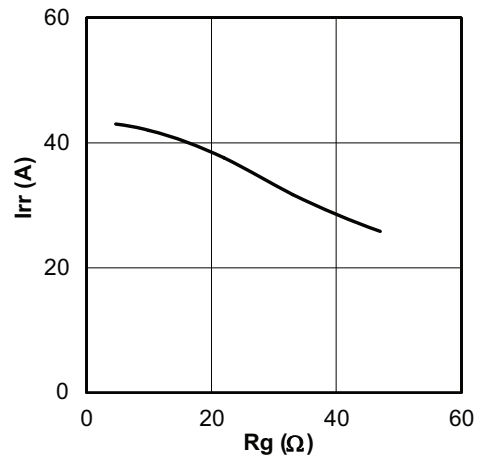

Fig. 14 - Typical Diode I_{RR} vs. R_G
 $T_J = 125^\circ\text{C}; I_F = 20\text{ A}$

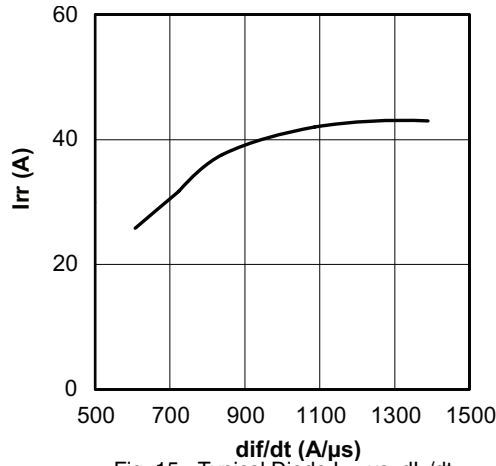

Fig. 15 - Typical Diode I_{RR} vs. di_F/dt
 $V_{CC} = 300\text{ V}; V_{GE} = 15\text{ V}; I_{CE} = 20\text{ A}; T_J = 125^\circ\text{C}$

THERMISTOR

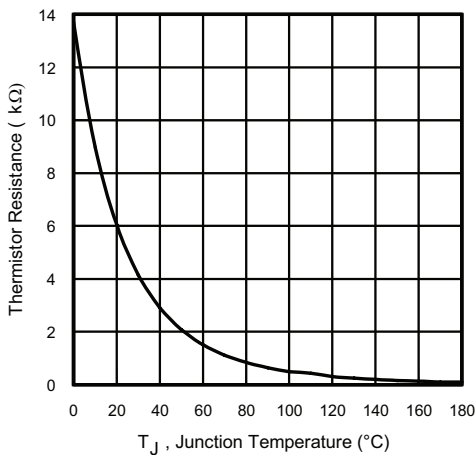

Fig. 16 - Thermistor Resistance vs. Temperature

INPUT RECTIFIER

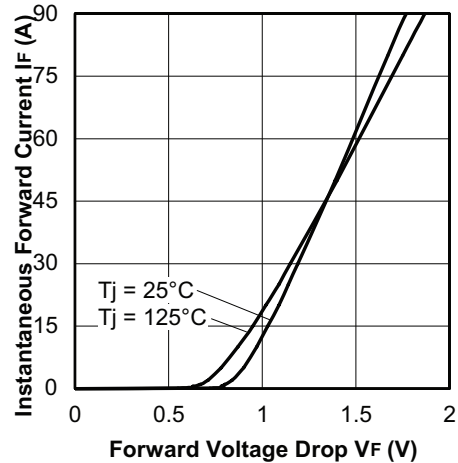

Fig. 17 - Typical Diode Forward Characteristics
 $t_p = 80\ \mu\text{s}$

INVERTER

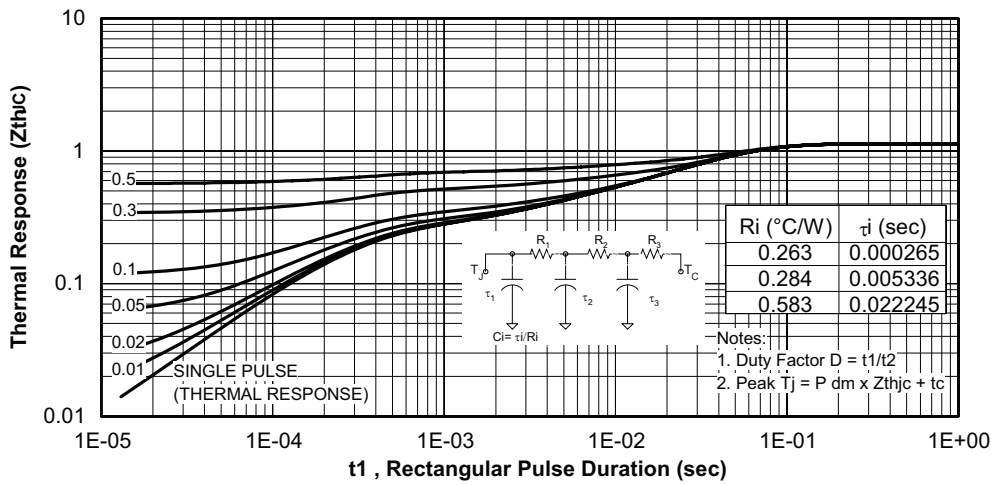

Fig. 18 - Maximum Transient Thermal Impedance, Junction to Case (Inverter IGBT)

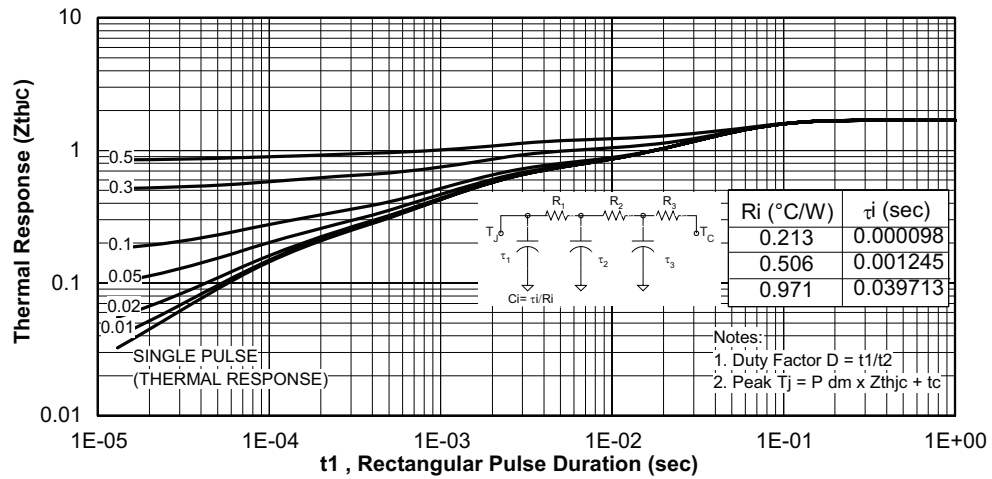
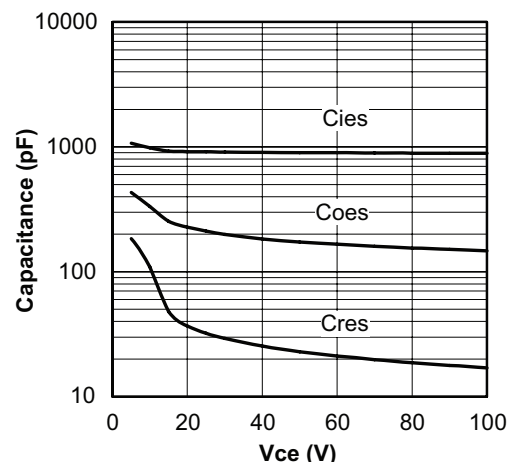
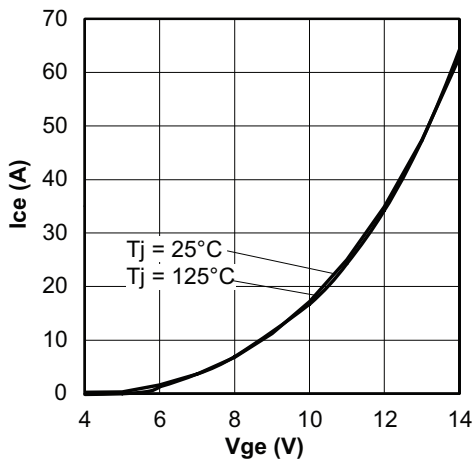
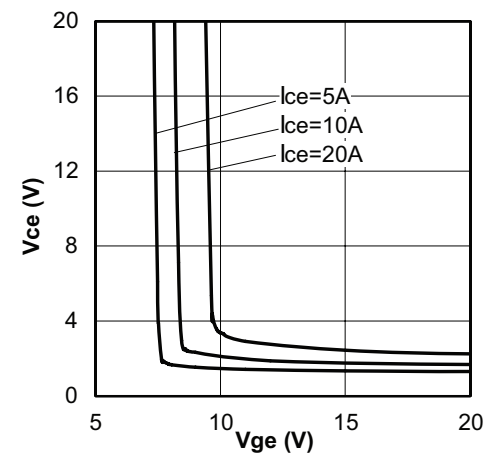
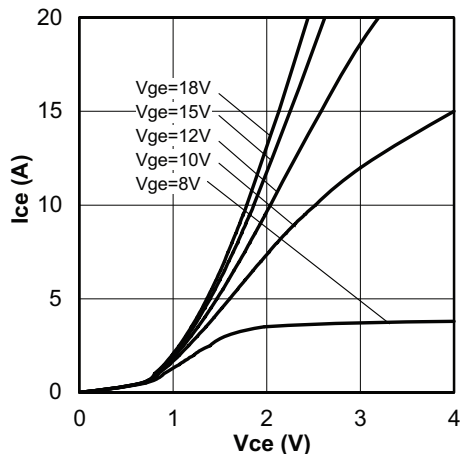
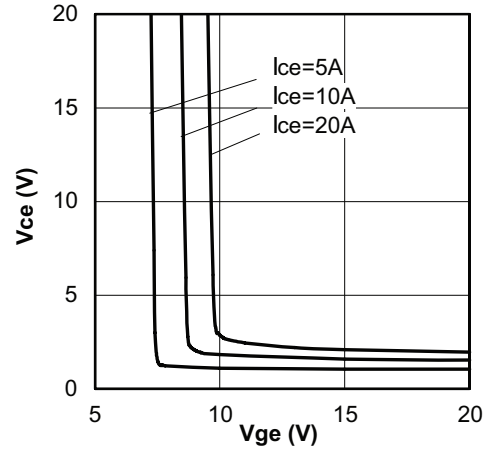
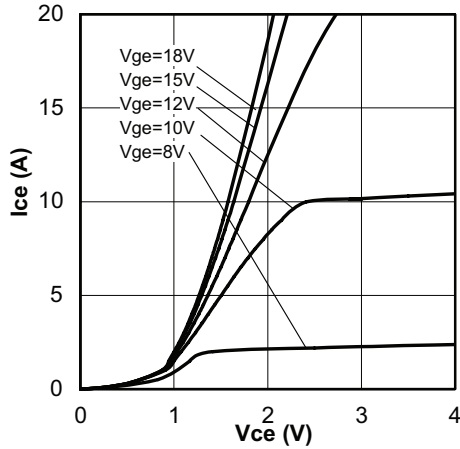

Fig. 19 - Maximum Transient Thermal Impedance, Junction to Case (Diode)

BRAKE

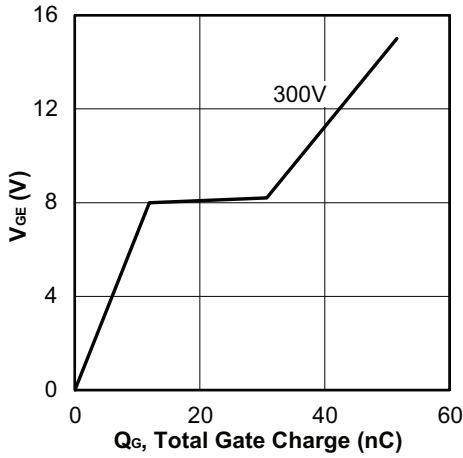

Fig. 26 - Typical Gate Charge vs. V_{GE}
 $I_{CE} = 10 \text{ A}$

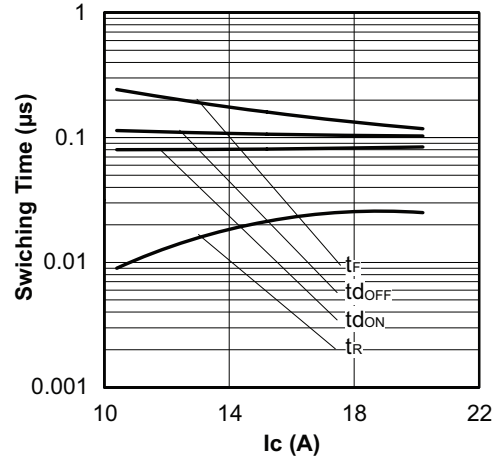

Fig. 29 - Typical Switching Time vs. I_C
 $T_J = 125 \text{ }^\circ\text{C}$; $L = 500 \text{ } \mu\text{H}$; $V_{CE} = 300 \text{ V}$; $R_G = 22 \text{ } \Omega$; $V_{GE} = 15 \text{ V}$

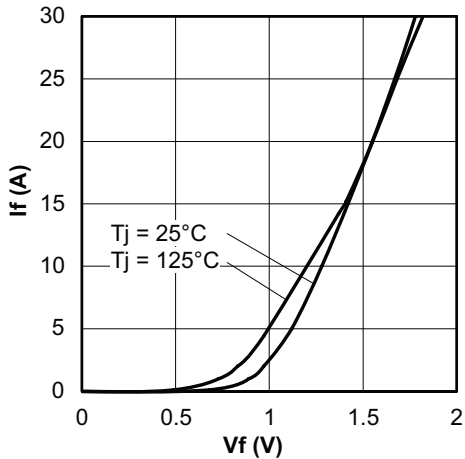

Fig. 27 - Typical Diode Forward Characteristics
 $t_p = 80 \text{ } \mu\text{s}$

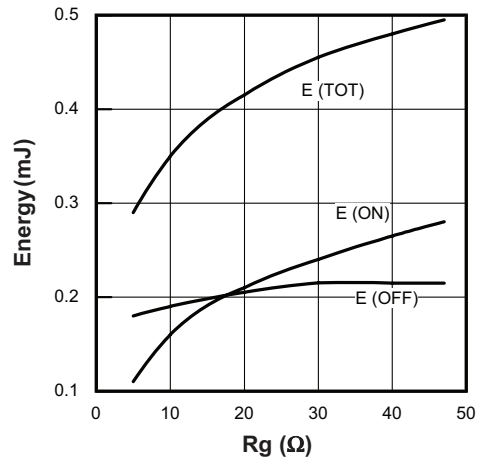

Fig. 30 - Typical Energy Loss vs. R_G
 $T_J = 125 \text{ }^\circ\text{C}$; $L = 500 \text{ } \mu\text{H}$; $V_{CE} = 300 \text{ V}$; $I_{CE} = 10 \text{ A}$; $V_{GE} = 15 \text{ V}$

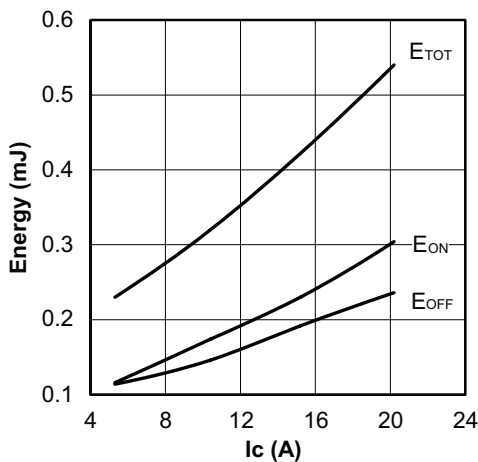

Fig. 28 - Typical Energy Loss vs. I_C
 $T_J = 125 \text{ }^\circ\text{C}$; $L = 500 \text{ } \mu\text{H}$; $V_{CE} = 300 \text{ V}$; $R_G = 22 \text{ } \Omega$; $V_{GE} = 15 \text{ V}$

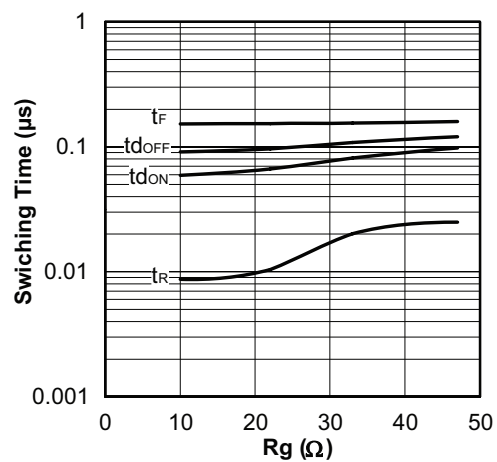

Fig. 31 - Typical Switching Time vs. R_G
 $T_J = 125 \text{ }^\circ\text{C}$; $L = 500 \text{ } \mu\text{H}$; $V_{CE} = 300 \text{ V}$; $I_{CE} = 10 \text{ A}$; $V_{GE} = 15 \text{ V}$

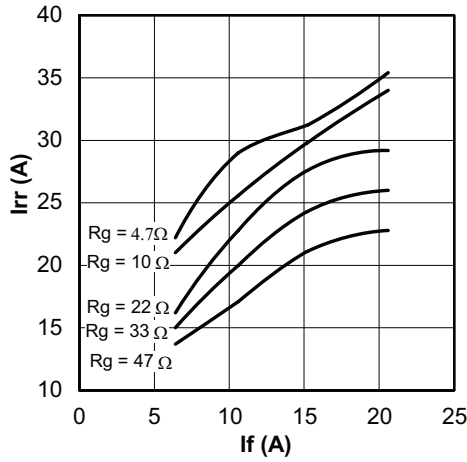

Fig. 32 - Typical Diode I_{RR} vs. I_F
 $T_J = 125^\circ\text{C}$

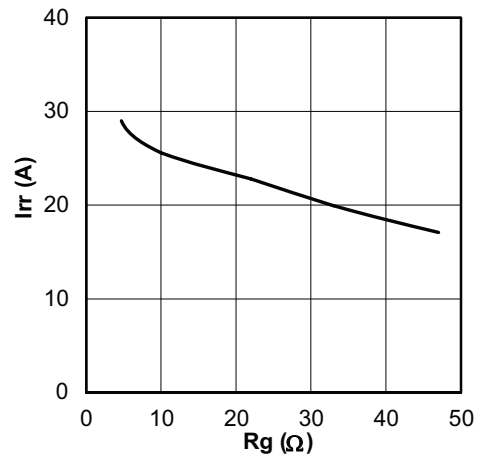

Fig. 33 - Typical Diode I_{RR} vs. R_G
 $T_J = 125^\circ\text{C}$; $I_F = 10\text{ A}$

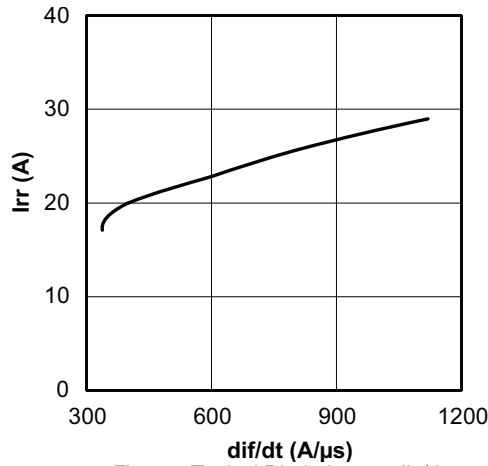

Fig. 34 - Typical Diode I_{RR} vs. di_F/dt
 $V_{CC} = 300\text{ V}$; $V_{GE} = 15\text{ V}$; $I_{CE} = 10\text{ A}$; $T_J = 125^\circ\text{C}$

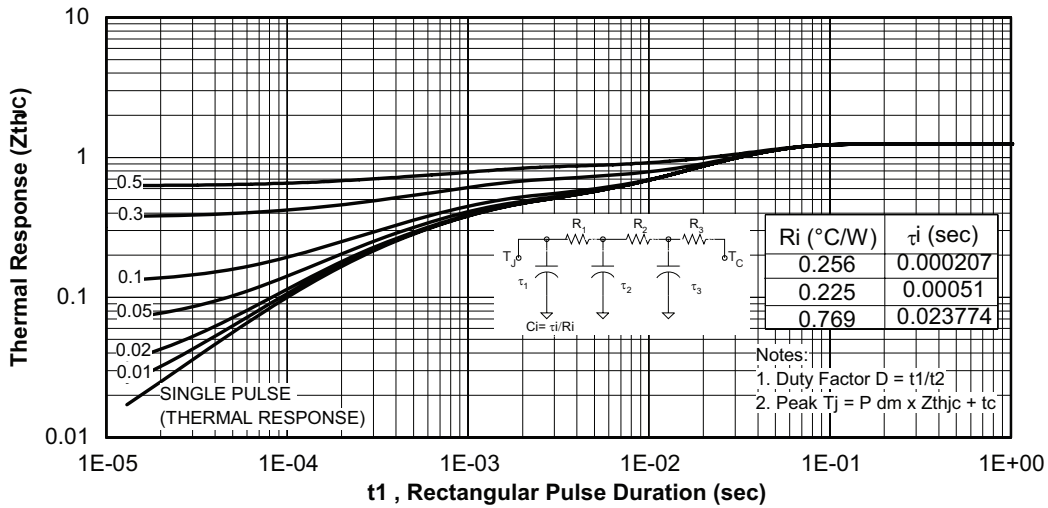

Fig. 35 - Maximum Transient Thermal Impedance, Junction to Case (Brake IGBT)

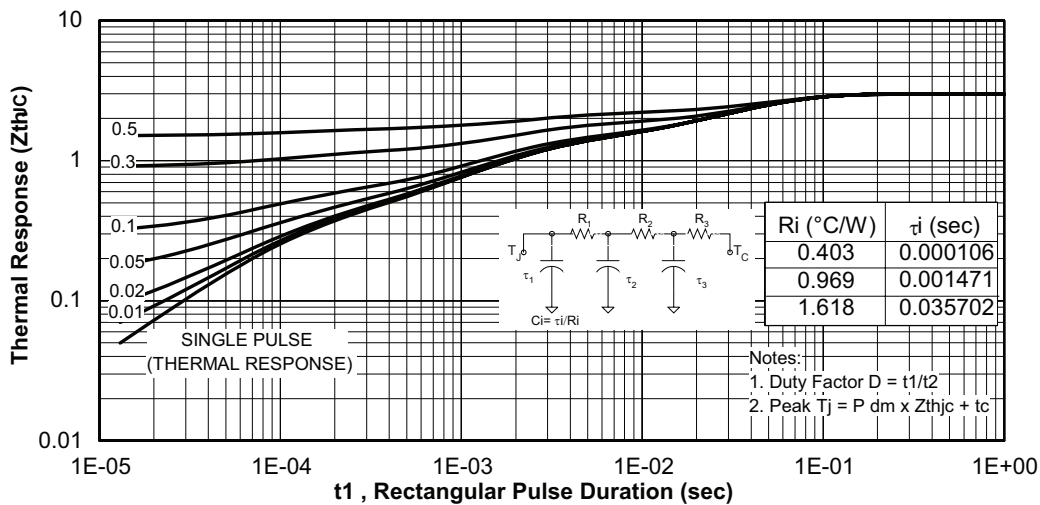

Fig. 36 - Maximum Transient Thermal Impedance, Junction to Case (Brake Diode)

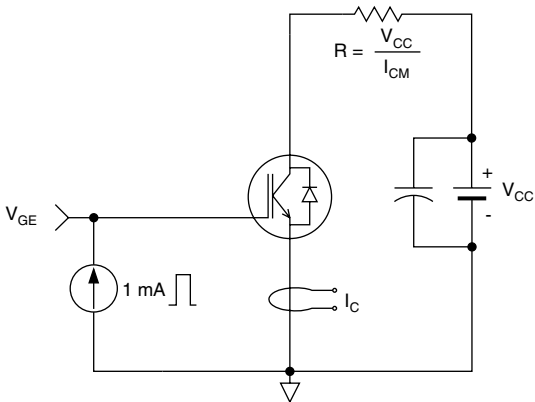

Fig. C.T.1 - Gate Charge Circuit (turn-off)

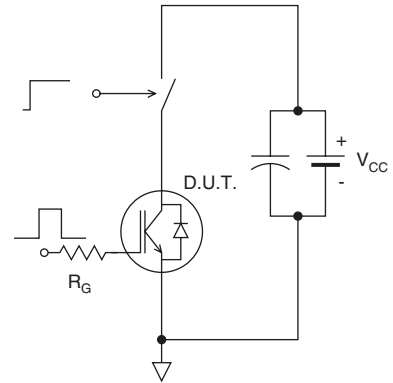

Fig. C.T.3 - S.C. SOA Circuit

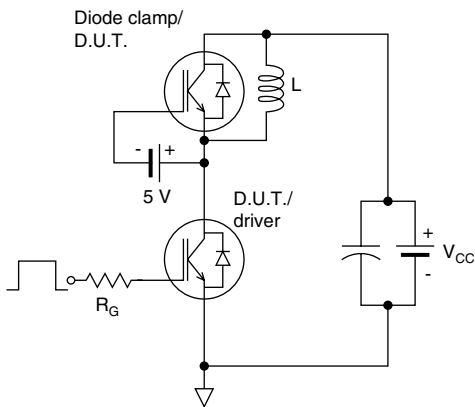

Fig. C.T.2 - RBSOA Circuit

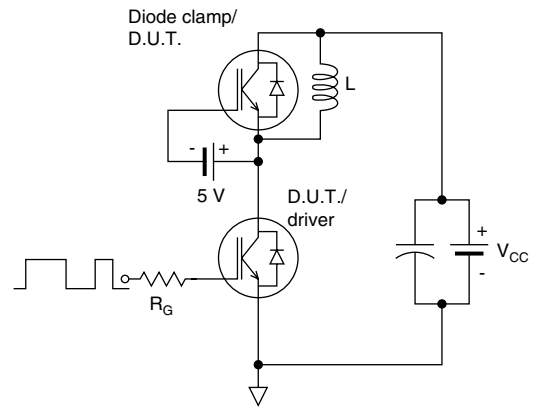

Fig. C.T.4 - Switching Loss Circuit

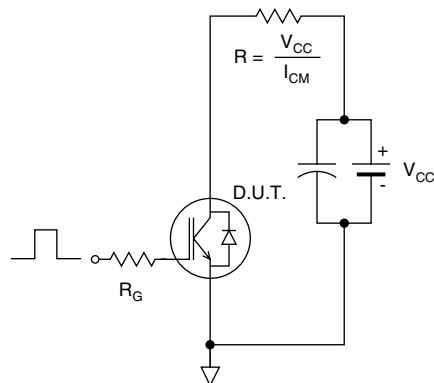
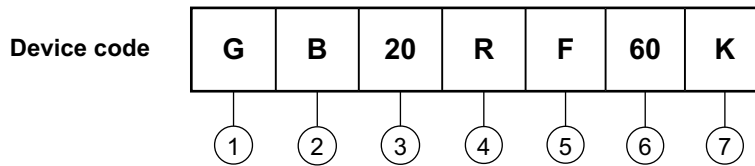

Fig. C.T.5 - Resistive Load Circuit

ORDERING INFORMATION TABLE



- 1** - Insulated Gate Bipolar Transistor (IGBT)
- 2** - B = IGBT Generation 5 NPT
- 3** - Current rating (20 = 20 A)
- 4** - Circuit configuration
(R = Three phase bridge-brake-inverter with thermistor)
- 5** - Package indicator (F = ECONO2)
- 6** - Voltage rating (60 = 600 V)
- 7** - Speed/type (K = Ultrafast IGBT/Speed 8 to 60 kHz)

CIRCUIT CONFIGURATION

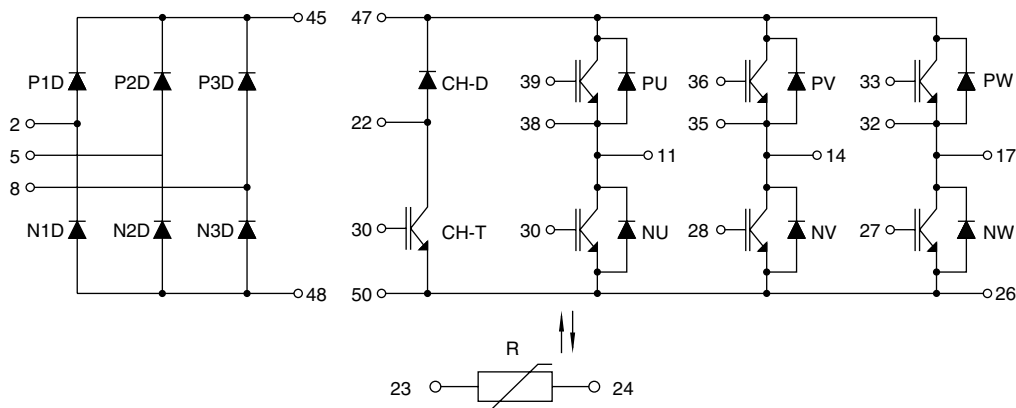

LINKS TO RELATED DOCUMENTS

Dimensions	http://www.vishay.com/doc?95083
Part marking information	http://www.vishay.com/doc?95071



Disclaimer

All product specifications and data are subject to change without notice.

Vishay Intertechnology, Inc., its affiliates, agents, and employees, and all persons acting on its or their behalf (collectively, "Vishay"), disclaim any and all liability for any errors, inaccuracies or incompleteness contained herein or in any other disclosure relating to any product.

Vishay disclaims any and all liability arising out of the use or application of any product described herein or of any information provided herein to the maximum extent permitted by law. The product specifications do not expand or otherwise modify Vishay's terms and conditions of purchase, including but not limited to the warranty expressed therein, which apply to these products.

No license, express or implied, by estoppel or otherwise, to any intellectual property rights is granted by this document or by any conduct of Vishay.

The products shown herein are not designed for use in medical, life-saving, or life-sustaining applications unless otherwise expressly indicated. Customers using or selling Vishay products not expressly indicated for use in such applications do so entirely at their own risk and agree to fully indemnify Vishay for any damages arising or resulting from such use or sale. Please contact authorized Vishay personnel to obtain written terms and conditions regarding products designed for such applications.

Product names and markings noted herein may be trademarks of their respective owners.